

# Electrochemical Corrosion in High Temperature Sub- and Supercritical Water

## Goal

The main goal of the project is to study electrochemical kinetics and corrosion processes of a number of metal alloys in high temperature subcritical and supercritical aqueous systems. The electrochemical measurements are conducted in a steady flow under well-established hydrodynamic conditions and this will allow measuring the corrosion rate and other kinetic parameters related to the electron transfer mechanism. An annular duct geometry hydrodynamics is being implemented in this project to separate the electron transfer reactions and mass transport processes.

## Team

Serguei Lvov, Principle Investigator  
Victor Balashov, Research Associate  
Mark Fedkin, Research Associate

This research project has been funded by NSF, DOE, ARO, and recently by Electric Power Research Institute.

The Energy Institute • [www.energy.psu.edu](http://www.energy.psu.edu)  
College of Earth & Mineral Sciences • Penn State University

## Background

To achieve the comprehensive understanding of interaction between a metal (or metal alloy) and a high temperature fluid electrochemical kinetics and corrosion studies must be carried out, and therefore, an electrochemical system capable to reliably operate at temperatures above 300 °C should be developed. As a matter of fact, almost no data is available on the exchange current densities and the anodic and cathodic transfer coefficients even for the most fundamental electrochemical reactions in high temperature subcritical and supercritical aqueous systems. Even the primary hydrogen electrode and oxygen electrode reaction have been poorly studied at temperatures above 100 °C. Also, almost no studies have been performed to experimentally measure the electrochemical corrosion current and potential in high temperature aqueous environments at temperatures above 300 °C. Therefore, the creation of a reliable method for studying the electrochemical kinetics and corrosion processes over a wide range of temperatures remains a serious and unresolved experimental problem. This project is aimed to solve this problem.

## Project Discussion

The methodology of this research will combine traditional methods of high-temperature electrochemistry, mass loss tests, and ex-situ specimen analysis. The corrosion rate and electrochemical kinetics measurements can be most efficiently performed using three different electrochemical methods: (1) DC polarization, (2) electrochemical impedance spectroscopy (EIS), and (3) electrochemical noise analysis (ENA). In this project, the above-listed methods are implemented in a high temperature flow-through electrochemical cell shown on the right. The cell body is made of a highly corrosion-resistant alloy, Hastelloy-B, and is designed for operating at temperatures up to 500°C. The electrochemical cell has four ports for installation of high-temperature electrodes and inlets and outlets of a test solution. The test solution is supplied with a high-pressure chromatography pump (HPCP), which has no metallic parts contacting the solution. The pressure is controlled by a pressure-relief valve and monitored using a pressure gauge. Heating is provided by the coil heaters wound over the cell body.

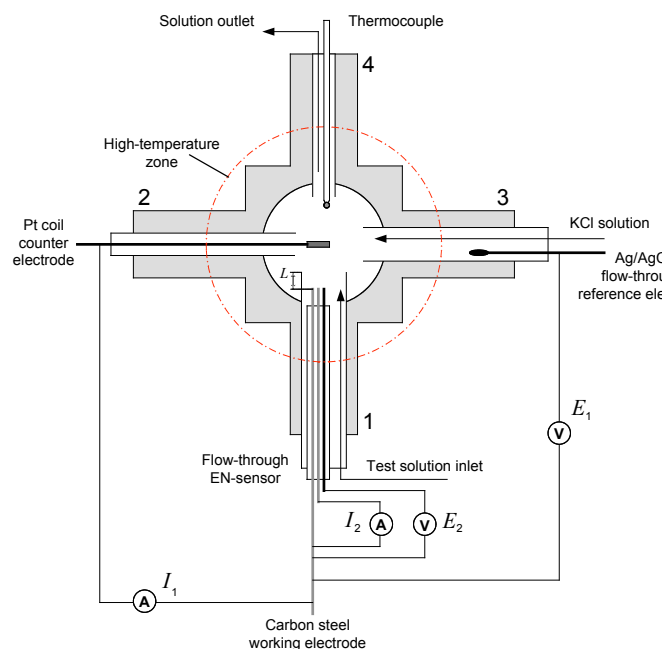

## Results

We have applied the electrochemical emission spectroscopy and developed an electrochemical noise sensor to show that this technique is capable to measure the electrochemical kinetics and corrosion rates in high temperature subcritical and supercritical hydrothermal systems.

The instrument shown on the right has been tested in flowing aqueous solutions containing NaCl and HCl at temperatures from 150 to 390 °C, a pressure of 25 MPa, and flow rates from 0.375 ml/min to 1.00 ml/min. The potential and coupling current noises from Type 304 stainless steel were simultaneously recorded. The inverse noise resistance was compared with the corrosion rate determined via mass loss tests. It was found that the inverse noise resistance correlated very well to the corrosion rate evaluated from mass loss tests, which was a function of temperature and flow rate. At temperatures higher than 150 °C, the corrosion rate was found to be proportional to the inverse noise resistance and, hence, Stern-Geary law could be used to evaluate the corrosion rate. A good agreement was found between the Stern-Geary constant evaluated via electrochemical noise analysis and that determined via polarization measurements.

It was also found that one of the important steps in configuring the high-temperature electrochemical cell for corrosion studies is to determine and test the most efficient electrode geometry, which would provide measurable corrosion current values. Based on comparative analysis, the annulus duct geometry was found preferable for the high-temperature cell configuration due to a higher magnitude of the limiting current (compared, for example, to the wall-tube geometry). The constructed working-counter electrode assembly employs the annular duct electrode geometry, in which the test solution flows between a working and counter electrodes.

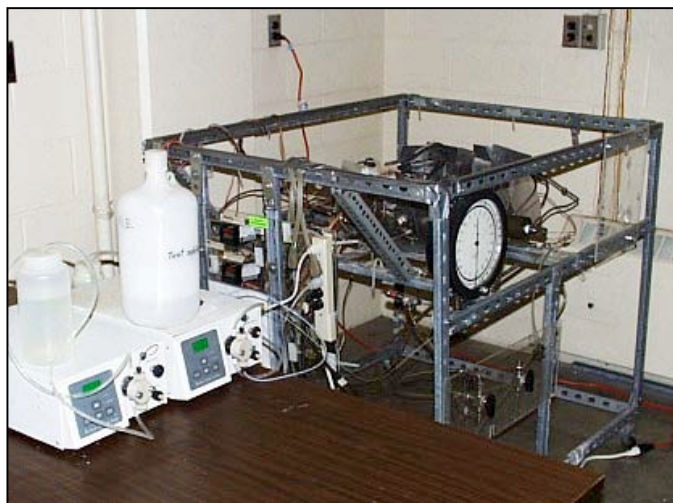

High temperature electrochemical system for corrosion measurements

Based on these studies, the electrochemical corrosion rate was estimated. Although the electrochemical emission spectroscopy has yet to be rendered quantitative, the results obtained thus far suggest that this method is an effective tool for studying the electrochemical kinetics phenomena in high temperature subcritical and supercritical aqueous solutions.

### Key Contacts

Serguei Lvov, [lvov@psu.edu](mailto:lvov@psu.edu), (814) 863-8377

Victor Balashov, [vnb1@psu.edu](mailto:vnb1@psu.edu), (814) 865-3280

Mark Fedkin, [mvf3@psu.edu](mailto:mvf3@psu.edu), (814) 865-3280

### Key Publications

S.N. Lvov, in *Encyclopedia of Electrochemistry* V. 6 (M. Stratmann and A. Bard, Eds.), Wiley-VCH (2005, in press).

S.N. Lvov and D.A. Palmer, in *The Physical and Chemical Properties of Aqueous Systems at Elevated Temperatures and Pressures: Water, Steam and Hydrothermal Solutions* (Eds.: D.A. Palmer, R. Fernández-Prini, and A.H. Harvey), Elsevier, Amsterdam, 377-408 (2004).

X.Y. Zhou, S.N. Lvov, X.J. Wei, L.G. Benning, and D.D. Macdonald, *Corrosion Sci.* **44**, 841 (2002).